

Assembly Instructions

- ACA0800
- ACA1200
- ACA1600

Fixings Supplied:

M6 x12 (16)



Use with flatwasher

M6 x30 (4)



Use with springwasher and flatwasher

M6 Wrench
x1

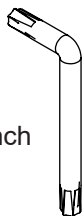

- Use M6 wrench to align all bolts.
- Be careful not to cross thread.
- Tighten all bolts when fully assembled.
- End and front panel can be removed for access to tighten wall/ground fixings.

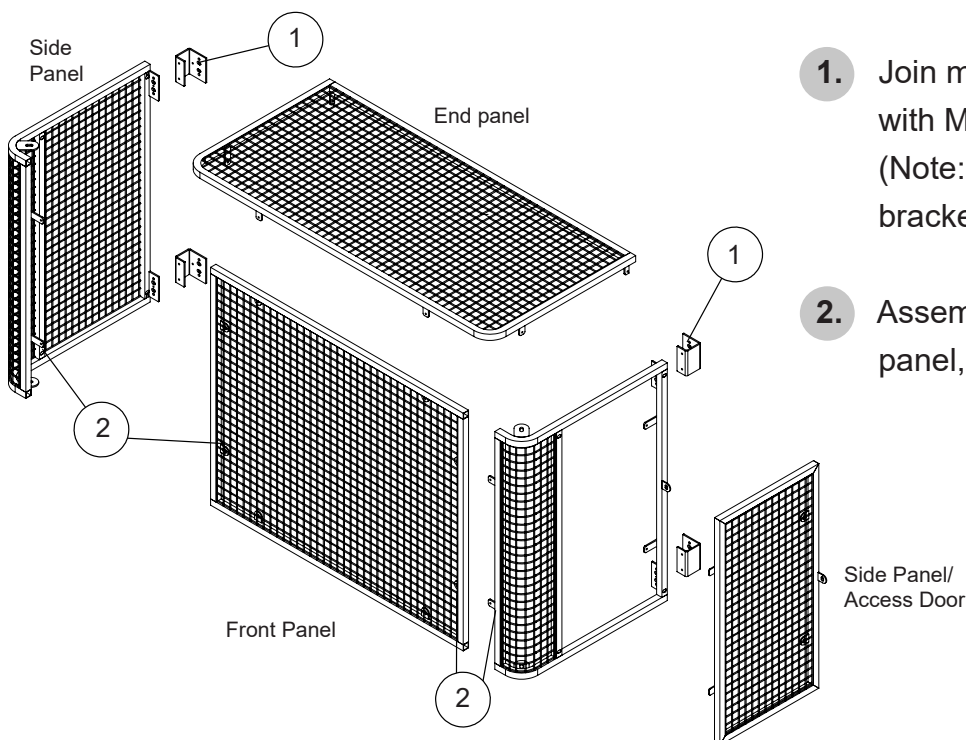

1. Join mounting brackets to side panel with M6 x12.
(Note: Cage can be mounted without brackets).
2. Assemble 2 side panels and front panel, using M6 x12.

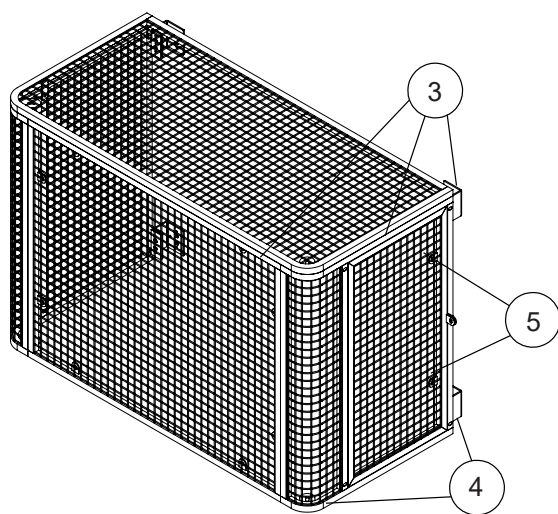

3. Fit end panel and secure with M6 x12 (2) and M6 x30 (4).
4. Fix cage to wall and ground as required.
5. Attach access door with M6 x12 (2) or padlock.