

ACB1200G

Specifications

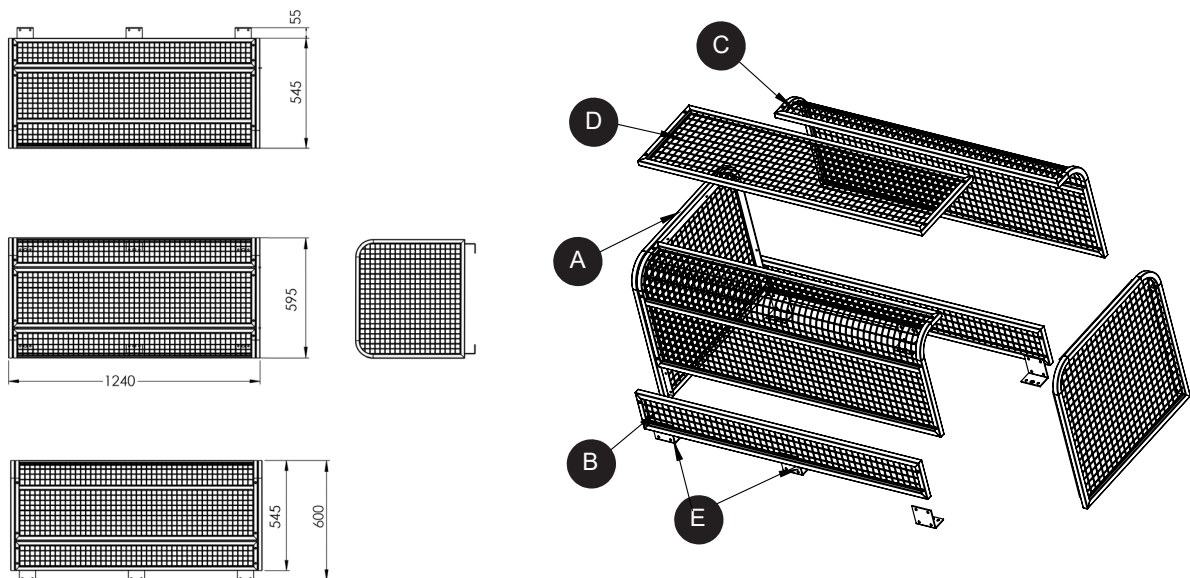

Frame	20 mm x 20 mm x 1.6 mm Welded Steel Tube
Mesh	25 mm x 25 mm x 3 mm Welded Mesh - Welded to Frame
Cage Depth	600 mm OD - 580 mm ID
Cage Width	595 mm OD - 555 mm wide IDØ
Cage Length	1240 mm OD, 1200 mm ID
Mounting Brackets	80 x 50mm Mounting Brackets, Optional holes allow the cage to be mounted, flush to the ground/to a wall, or with 25mm or 50mm clearance for pipes and conduits
Cage Safety	Corners are 90 mm radius to minimise personal injury
Assembly Required	Units are made up of the following parts (see diagram) A - End Panels (2) B - Side Panels (2) C - Corner Panels (2) D - Front Panel (1) E - Brackets (6) F - Fixings M6x12 (12), M6x30 (30)
Service Access	All panels (except sidepanels) are easily removable for full service access
Assembly Fixings	All Fixings supplied - M6 tamper proof Torx bolts, washers and tool
Optional End Panel	Available - Part No EPB0001
Coating	Two stage protection with Hot Dip Galvanised and Black Powder Coating



© 2024 Avantage Australia reserves the right to alter products and specifications without notice and does not accept responsibility for possible errors and omissions in published documentation.
Date: 20/10/2024 Document: Avantage Airshield Cages ACB1200G Spec Sheet Version Number: V3

T: 03 9989 5850 W: avantageaustralia.com.au
E: sales@avantageaustralia.com.au