

# Assembly Instructions

## PARTS INCLUDED

- A** END PANELS (2)
- B** SIDE PANELS (4)
- C** CORNER PANELS (4)
- D** FRONT PANELS (2)
- E** BRACKETS (12)
- F** FIXINGS – M6x12 (12), M6x30 (30)
- G** JOINING FRAME (1)

- Be careful not to cross thread fixings.
- Tighten all bolts when fully assembled.

## • ACB2400G

ACB2400G is assembled using 2x ACB1200G plus a JFB0001 joining frame.

ACB Protection Cages are usually installed horizontally with two end panels and the mounting brackets fixed to the ground.

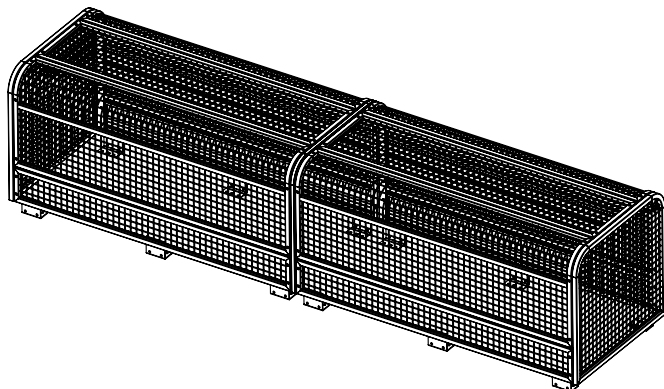
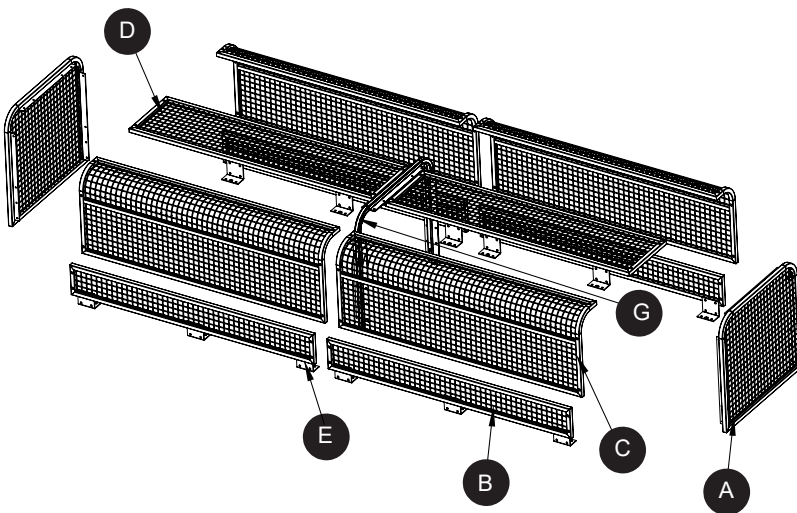

- 1** Attach the BRACKETS (E) to the SIDE PANELS (B) with M6x12 bolts. Optional holes allow the cage to be mounted, flush to the ground/to a wall, or with 25mm or 50mm clearance for pipes and conduits.
- 2** Attach the SIDE PANELS (B) to the END PANELS (A) using M6x30 bolts.
- 3** Attach the SIDE PANELS (B) to the JOINING FRAME (G) using M6x30 bolts.
- 4** Attach the 4 x CORNER PANEL (C) to the END PANELS (A) & JOINING FRAME (G) using M6x30 bolts.
- 5** Position the cage in the desired location. Check the cage is level horizontally and vertically.
- 6** Fix the cage to the ground using suitable anchors (not supplied).
- 7** Add the remaining PANELS and tighten all fixings to complete the installation.