

Assembly Instructions

PARTS INCLUDED

- A** END PANELS (2)
- B** SIDE PANELS (2)
- C** CORNER PANELS (2)
- D** FRONT PANELS (1)
- E** BRACKETS (6)
- F** FIXINGS – M6x12 (12), M6x30 (30)

- Be careful not to cross thread fixings.
- Tighten all bolts when fully assembled.

- **ACB0800G**
- **ACB1200G**
- **ACB1600G**

ACB Protection Cages are usually installed horizontally with two end panels and the mounting brackets fixed to the ground.

An optional Base Frame is available which can be used instead of one end panel for a vertical ACB Cage installation.

An optional ACB Joining Frame is available to join multiple cage lengths together.

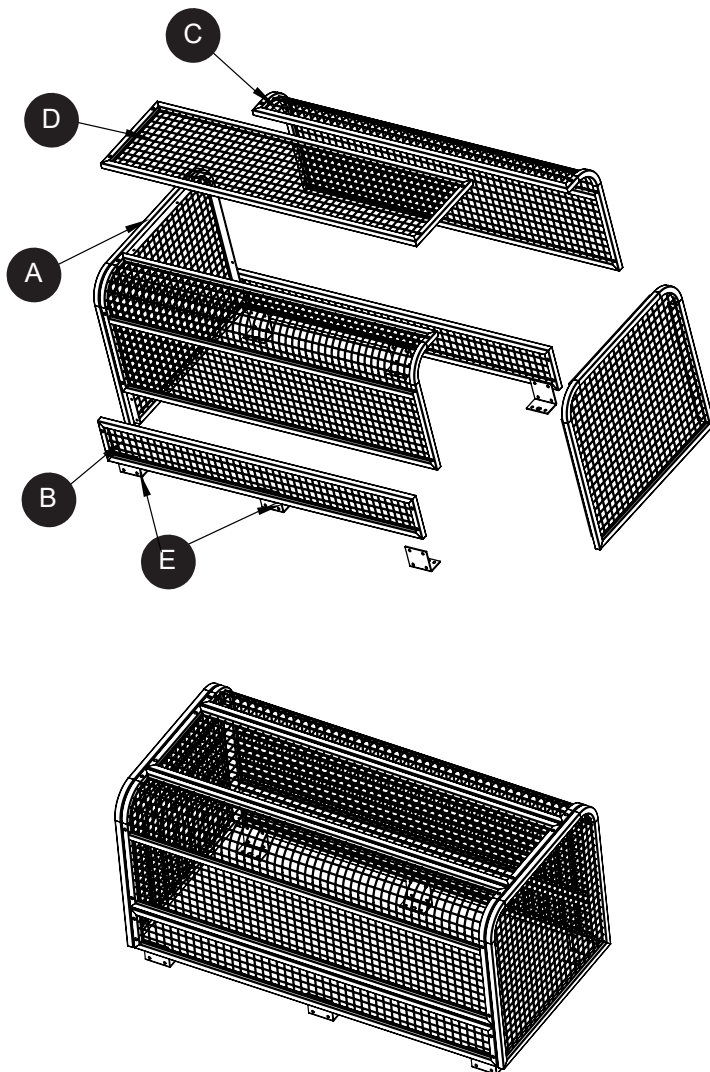

- 1** Attach the BRACKETS (E) to the SIDE PANELS (B) with M6x12 bolts. Optional holes allow the cage to be mounted flush to a wall or with 25mm or 50mm clearance for pipes and conduits.
- 2** Attach the SIDE PANELS (B) to the END PANELS (A) using M6x30 bolts.
- 3** Attach one CORNER PANEL (C) or the FRONT PANEL (D) to the END PANELS (A) using M6x30 bolts.
- 4** Position the cage in the desired location. Check the cage is level horizontally and vertically.
- 5** Fix the cage to the ground or wall using suitable anchors (not supplied).
- 6** Add the remaining PANELS and tighten all fixings to complete the installation.