

Assembly Instructions

- EPA0001
- EPB0001
- EPC0001

Fixings Supplied:

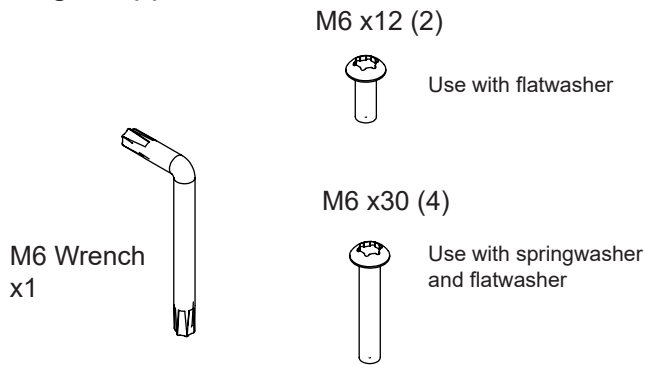

- Use M6 wrench to align all bolts.
- Be careful not to cross thread.
- Tighten all bolts when fully assembled.

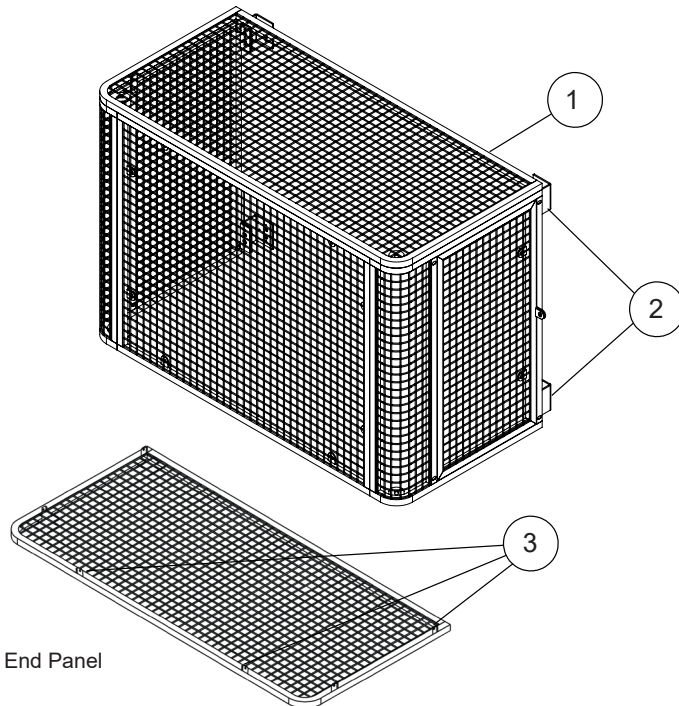

Additional End Panel to create a fully enclosed cage.

1. Assemble cage.
2. Fix cage to wall or ground as required.
3. Fit additional End Panel and secure with M6x12 (2) and M6x30 (4).

