

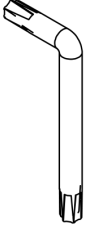
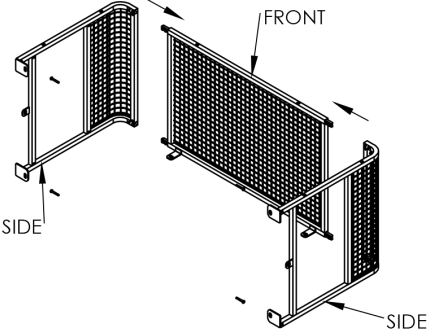
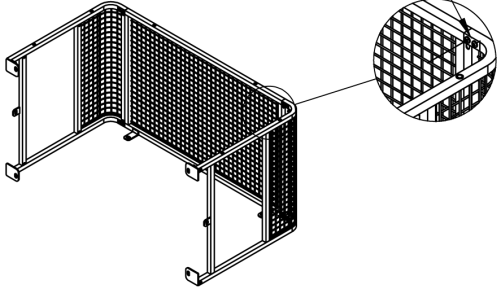
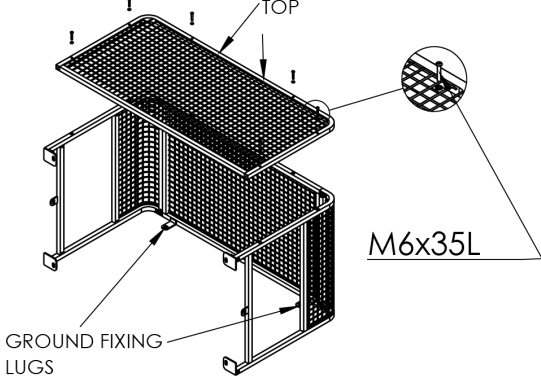
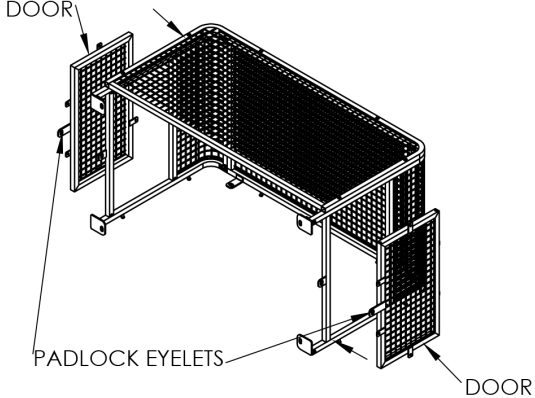

Airshield Cage

ASSEMBLY INSTRUCTIONS

<p>FIXINGS SUPPLIED</p> <p> M6x16L x6 (for 600mm & 800mm high) x12 (for 1200mm, 1400mm & 1600mm high)</p> <p> M6x35L x6</p> <p> M6 Wrench x1</p>	<p>1 SLIDE LEFT AND RIGHT SIDE PANELS OVER JOINING LUGS ON FRONT PANEL.</p> 
<p>2 USING M6x16 BOLTS PROVIDED, JOIN SIDES AND FRONT TOGETHER. <u>DO NOT FULLY TIGHTEN AT THIS STAGE.</u></p> <p>M6x16L x8 (for 600mm & 800mm High) x12 (for 1200mm, 1400mm & 1600mm High)</p> 	<p>3 USING M6x35 BOLTS, JOIN TOP PANEL TO SIDES AND FRONT. ENSURE GROUND FIXING LUGS ON FRONT IS AT THE BOTTOM. TIGHTEN ALL SCREWS ON TOP, SIDES AND FRONT.</p> 
<p>4 DOOR MAY BE PADLOCKED THROUGH EYELETS PROVIDED OR SCREWED SHUT WITH METAL DRILLING SCREWS (metal drilling screws not provided).</p> 	<p>5 FINISHED FIXED TO WALL AND BASE USING APPROPRIATE FIXINGS (not provided).</p> 